



PNEUMAX



SOLENOID VALVES SAFELINE

VALVES AND SAFETY SYSTEMS



PNEUMAX

Pneumax

Smart Technologies and Human Competence

Founded in 1976, **Pneumax S.p.A.** is today one of the leading, international manufacturers of components and systems for industrial automation. It is at the fore front of a group comprised of 23 companies, with over 660 employees worldwide. Ongoing investment in research and development has allowed **Pneumax** to continually expand its range of standard products and customised solutions, adding to the well-established pneumatic technology, a range of electric drive actuators and fluid control components.



The ability to provide various technologies and solutions for each of our clients applications is the main objective of the Company, making **Pneumax** the ideal strategic partner.

What defines us is the “Pneumax Business Attitude”, born out of the capacity to combine industry sectors, technology and our application skills via the clients collaboration with our business and product specialists. This represents the main **Pneumax** distinguishing factor.



**Pneumatic
technology**



**Electric
actuation**



**Fluid
control**



Index



Solenoid valve for the interruption and discharge of the air supply 3/2 G1/2" - Compact series 412/2

General	3
Single version 3/2 Solenoid-Spring	6
Double version 3/2 Solenoid-Spring	7



Solenoid valve for the interruption and discharge of the air supply 5/2 - Series 1000 ISO 5599/1

General	8
Single version 5/2 Solenoid-Spring (ISO1, ISO2, ISO3)	11
Single use bases	13
Double version 5/2 Solenoid-Spring (ISO1, ISO2, ISO3)	14



Compact series 412/2

General

This solenoid valve, version 412/2 G1/2" is the compact version of its standard namesake. "A reliable, robust and well consolidated Pneumax product". It has been developed with new adapted characteristics to be included in secure pneumatic circuits where it is necessary to interrupt and exhaust the air supply when the electro-pneumatic command is de-energised.

The valve is based on balanced spool technology which has 3 ports, 2 positions and is normally closed.

The electro-pneumatic valve is actuated using a 15mm solenoid valve from the Pneumax 300 Series range and repositioned by the internal return spring.

The air supply used by the solenoid valve can be supplied in 2 different ways;

- **Self Feeding:** supplied directly by the air being controlled (subject to a minimum pressure);
- **External Feed:** supplied indirectly by an external air supply

The new feature in this version is the introduction of a diagnostic system able to monitor the ON/OFF state of the valve, with the possibility of increasing the level of monitoring using a double redundant system configured on a base which can be installed to control the management of the pneumatic connections.

The state of the valve is constantly monitored by a diagnostic system using a hall effect sensor with a 2.5 m, 3 wire cable, which reads the position of the spool and consequently the ON/OFF state.

- **Sensor is in the ON position** when the valve is at rest;
- **Sensor is in the OFF position** when the valve is activated

OPERATION OF THE COMPACT SERIES 412/2 WITH SINGLE OR DOUBLE CHANNEL, S.V. 3/2 N.C. MONOSTABLE WITH ELECTROPNEUMATIC COMMAND AND SPRING RETURN

Phases:

- **VALVE AT REST:** the coil is DE-ENERGISED, port 1 (air supply) is not connected to port 2 (downstream air circuit). Port 2 is exhausted out of port 3;
- **VALVE ACTIVATED:** the coil is ENERGISED, port 1 (air supply) is connected to port 2 (downstream air circuit) with port 3 (exhaust port) closed.

By de-energising the coil, the system resets the condition of VALVE AT REST by means of the return spring, which repositions the spool. Once again Port 2 (downstream air circuit), exhausts via Port 3.

The electrical connection is provided through the connector to the series 300 15mm solenoid valve. Please note: With the connector fitted the IP Rating is IP65.

The SAFELINE supply and discharge valve in the single version is a classified component in CATEGORY 2 according to ISO EN 13849 and is appropriate for use in safety circuits until PL=C.

The version with a double redundant version is made using two single solenoid valves 3/2 N.C. provided with diagnostics, mounted in series so that the Port 2 of the first solenoid valve is connected to the Port 1 of the second solenoid valve. It is sufficient that only one of the S.V. is de-energised to guarantee the discharge of the air circuit. If one of the two S.V. must remain blocked due to a malfunction, the other one ensures the discharge function of the pneumatic installation. Even in this case, the diagnostic system of both solenoid valves constantly monitors the state of the 2 single S.V.

The SAFELINE supply and discharge valve in the double version is a classified component in CATEGORY 4 according to ISO EN 13849 and is appropriate for use in safety circuits until PL=E.

Both single and double solenoid valves are provided with the following certifications released by BUREAU VERITAS:

- TYPE APPROVAL certificate according to the EN ISO 13849 regulations
- certification of examination of compliance in accordance to the machinery directive 2006/42/CE

The AIRPLUS SAFELINE are solenoid valves marked as ATEX



II 3G Ex h IIB T4 Gc (X)
II 3D Ex h IIIC T135°C Dc (X) IP65
(-10°C ≤ Ta ≤ +50°C)

Construction characteristics

Body	Aluminium
Solenoid operator	Aluminium
Rear end cap	Aluminium
Spool	Aluminium
Spool seals	Polyurethane
Piston	Aluminium
Spring	EN 10270-1 DH steel
Electrical Interface	15mm connector

Operational characteristics

Description	Value
Fluid	Filtered air, if lubricated, the lubrication must be continuous
Working Temperature	-10°C - +50°C
Working Pressure, MIN	2,5 bar
Working Pressure, MAX	10 bar

Assembly and installation

Undertake the installation respecting the safety requirements with regards to the system and components for both hydraulic and pneumatic transmissions. Install the device as close as possible to the point of use. Its assembly is possible in any position. Pay attention to the flow direction, following the port numbers on the valve body. During the components discharge, high levels of noise occur. The use of a silencer on the discharge port is recommended. Ensure there is sufficient space for the assembly during the installation process. Please ensure that the discharge area is always clear, and in case a silencer is used, periodically verify that it is not obstructed.

WARNING:



Pay particular attention to external factors such as the nearness of live wires, magnetic fields, metallic objects providing magnetic conduction very close to the device, which may influence and disturb the diagnostic system.



The electrical connection must be made exclusively by qualified personnel, using components that have no voltage present. Only use power supplies which can guarantee a safe electrical isolation of the working voltage in accordance to IEC/EN 60204-1. Additionally, observe the requirements anticipated by the PELV circuits in accordance to IEC/EN 60204-1.

CARE AND MAINTENANCE:



Do not connect or disconnect the device when energised! Do not open and/or disassemble the parts that are included in the energised valve. Once the power supply is disconnected, wait for a few minutes before opening or disassembling parts of the valve that result in its disassembly.

Before carrying out any operation, it is essential to remove the pneumatic and power supply to the device and wait for the residual pressure to be completely discharged. Please ensure that the discharge is always clear, and in case a silencer is used, periodically verify that it is not obstructed. Periodically remove any dust deposits from the valve using a damp cloth. Use soapy water to clean the device. Do not use corrosive or alcohol-based products. For maintenance operations on internal components, please consult with PNEUMAX SPA.



REGULATORY FRAMEWORK:

The purpose of the EU' s Machinery Directive is to define the health and safety requirements in the framework of designing and constructing machinery. Since 2009, the new Machinery Directive has become effective in the European Union. Member countries of the EU are required to implement this standard. The manufacturers of machinery can comply with the Machinery Directive applying the harmonised standards listed in the Official Journal of the European Union. The design and manufacture of safety controls are developed in compliance with one of the two important harmonised standards:

UNI EN ISO 13849-1

Safety of machinery
Safety-related parts of control systems
Part 1: General design principles

EN 62061

Safety of machinery
Functional safety of electrical, electronic and programmable control systems regarding safety

The UNI EN ISO 13849-1 standard is one of the most important harmonised standards, which has been widely used; it is intended to provide a guide to principles for design and integration of safety-related parts of the control system.

Each safety-related control system must be designed and constructed in accordance with the principles of ISO 12100 and ISO 14121 by which the possible risks are considered and assessed, in view of the intended uses and the reasonably anticipated incorrect uses.

The parts of a machinery' s control system are called "Safety-related parts of control systems". Their capacity to perform a safety function under predictable conditions is assigned by means of five possible levels called "performance levels" (PL). These levels are defined in terms of probability of dangerous malfunction per hour.

PL - Performance Level	Average probability of dangerous malfunction per hour (1/h)
a	$\geq 10^{-5}$ to $< 10^{-4}$
b	$\geq 3 \times 10^{-6}$ to $< 10^{-4}$
c	$\geq 10^{-6}$ to $< 3 \times 10^{-6}$
d	$\geq 10^{-7}$ to $< 10^{-6}$
e	$\geq 10^{-8}$ to $< 10^{-10}$

The calculated PL must be greater or equal to the necessary value, which arises from the calculation of the risk correlated to one single function and to the need to reduce it to an acceptable level:

S1 Slight danger	F1 Occasional danger and brief exposure	P1 - possibly avoidable danger P2 - largely unavoidable danger	PL = a PL = b
	F2 Frequent danger and long exposure	P1 - possibly avoidable danger P2 - largely unavoidable danger	
S2 Serious danger	F1 Occasional danger and brief exposure	P1 - possibly avoidable danger P2 - largely unavoidable danger	PL = c PL = d
	F2 Frequent danger and long exposure	P1 - possibly avoidable danger P2 - largely unavoidable danger	

Single version 3/2 Solenoid-Spring



Ordering code	
412/2.32.0.1.V.VS.1	
AIR SUPPLY	
V	= Self Feeding
E	= External Feed
15 mm COIL VOLTAGE	
01	= 24 V DC
02	= 12 V DC
1	05 = 24 V AC (50 - 60 Hz)
	06 = 110 V AC (50 - 60 Hz)
	07 = 230 V AC (50 - 60 Hz)
	08 = 24 V DC (1 Watt)
Weight 600 g	
Minimum working pressure 2,5 bar	

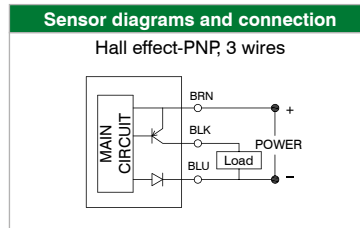
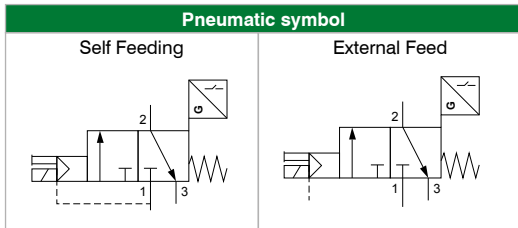
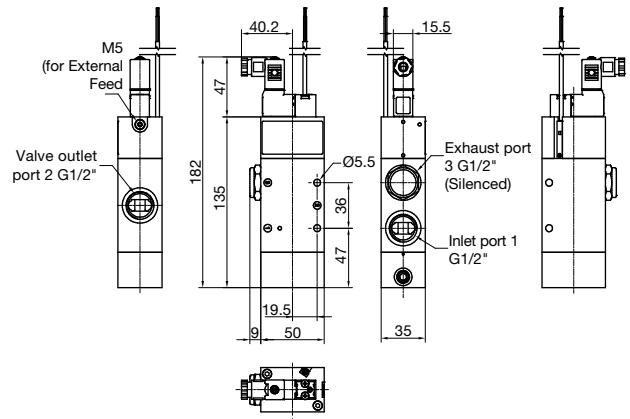

General technical features	
UNI-ISO 228/1 connections	G 1/2" (M5 external piloting)
Fluid	Filtered air, if lubricated, the lubrication must be continuous
Function	3/2 N.C. monostable
Working pressure	Vacuum - 10 bar
Piloting pressure	2,5 bar - 10 bar
Working temperature	-10°C - +50°C
Flow rate from 1 → 2 at 6 bar Δp1	4000 Nl/min
Flow rate from 2 → 3 at 6 bar Δp1	4000 Nl/min
Flow rate from 2 → 3 at 6 bar with free discharge	7200 Nl/min
Type of installation	Indifferent
Mounting	Individual bases
Noise level (with silenced exhaust)	70 dB
Response time ON ISO 12238 (TRA)	33 ms
Response time OFF ISO 12238 (TRR)	76 ms
General electrical features	
Solenoid valve	300 series 15 mm
Electrical connection	Faston/Connector Series 300
Coil features	24 VDC 1 W - 2.3 W / 12 VDC 2.3 W 24 VAC 50-60 Hz, 110 VAC 50-60 Hz, 230 VAC 50-60 Hz
Supply voltage allowance	-5% / +10%
IP Rating	IP65 (with connector installed)
Electrical features of sensor	
Voltage range	10 - 30 V DC
Operating principle	Hall effect
Contact type	N.O.
Output type	PNP
Permanent maximum current	100 mA
Permanent maximum power	3 W max.
Maximum load (inductive)	3 W max.
Voltage drop, MAX	1.5 V max.
Cable section	3x0.14 mm ² Ø3.3mm PUR
IP Rating	IP67
Working temperature	-10°C / + 70°C
Safety features	
Regulatory Compliance	EN ISO 13849-1
Safety Function Fulfilled	Interruption of supply and discharge of the pneumatic circuit connected to port 2
Performance Level (PL)	Up to c
UNI EN 13849 Category	Up to 2
Safety Integrity Level (SIL)	Up to 1
B10d Expected	20 x 10 ⁶ cycles
ATTENTION: in accordance with UNI EN ISO 13849-1, the T10D value must be calculated by the final system integrator based on the number of cycles per year of the components. In any case, the components must be replaced every twenty years.	
CE Marking	Safety component according to directive 2006/42/CE

Double version 3/2 Solenoid-Spring



Ordering code	
412/2.V2SB.1	
AIR SUPPLY	
V	= Self Feeding
E	= External Feed
15 mm COIL VOLTAGE	
01	= 24 V DC
02	= 12 V DC
05	= 24 V AC (50 - 60 Hz)
06	= 110 V AC (50 - 60 Hz)
07	= 230 V AC (50 - 60 Hz)
08	= 24 V DC (1 Watt)
Weight 2600 g	
Minimum working pressure 2,5 bar	

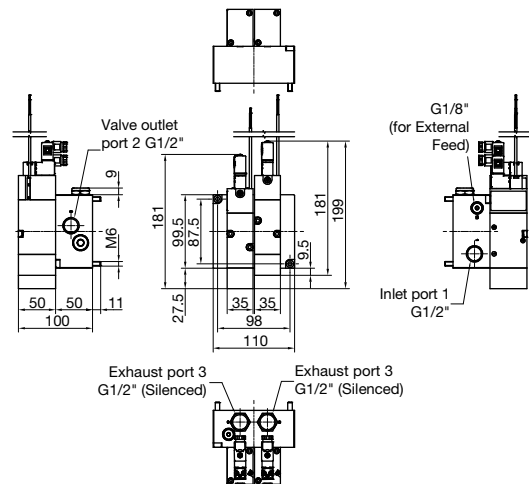
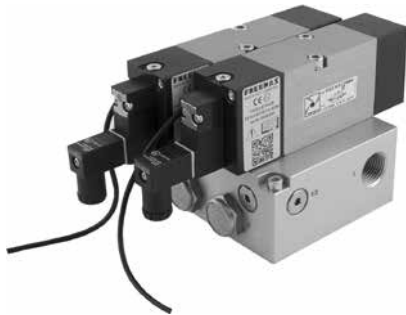

SOLENOID VALVES

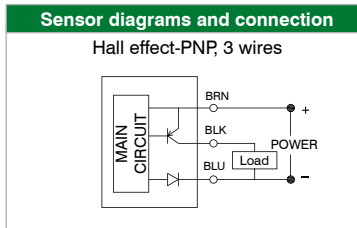
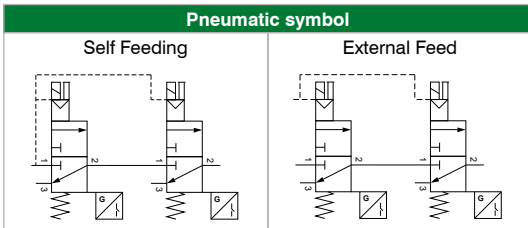

General technical features	
UNI-ISO 228/1 connections	G1/2" (G1/8" external piloting)
Fluid	Filtered air, if lubricated, the lubrication must be continuous
Function	3/2 N.C. monostable
Working pressure	Vacuum - 10 bar
Piloting pressure	2,5 bar - 10 bar
Working temperature	-10°C - +50°C
Flow rate from 1 → 2 at 6 bar Δp1	2500 NI/min
Flow rate from 2 → 3 at 6 bar Δp1	2300 NI/min
Flow rate from 2 → 3 at 6 bar with free discharge	4500 NI/min
Type of installation	Indifferent
Noise level (with silenced exhaust)	70 dB
Response time ON ISO 12238 (TRA)	38 ms
Response time OFF ISO 12238 (TRR)	80 ms
General electrical features	
Solenoid valve	300 series 15 mm
Electrical connection	Faston/Connector Series 300
Coil features	24 VDC 1 W - 2.3 W / 12 VDC 2.3 W 24 VAC 50-60 Hz, 110 VAC 50-60 Hz, 230 VAC 50-60 Hz
Supply voltage allowance	-5% / +10%
IP Rating	IP65 (with connector installed)
Electrical features of sensor	
Voltage range	10 - 30 V DC
Operating principle	Hall effect
Contact type	N.O.
Output type	PNP
Permanent maximum current	100 mA
Permanent maximum power	3 W max.
Maximum load (inductive)	3 W max.
Voltage drop, MAX	1.5 V max.
Cable section	3x0.14 mm ² Ø3.3mm PUR
IP Rating	IP67
Working temperature	-10°C / + 70°C
Safety features	
Regulatory Compliance	EN ISO 13849-1
Safety Function Fulfilled	Interruption of supply and discharge of the pneumatic circuit connected to port 2
Performance Level (PL)	Up to e
UNI EN 13849 Category	Up to 4
Safety Integrity Level (SIL)	Up to 3
B10d Expected	20 x 10 ⁶ cycles
ATTENTION: in accordance with UNI EN ISO 13849-1, the T10D value must be calculated by the final system integrator based on the number of cycles per year of the components. In any case, the components must be replaced every twenty years.	
CE Marking	Safety component according to directive 2006/42/CE



Series 1000 ISO 5599/1

General

This solenoid valve, version ISO1, ISO2, ISO3 is the version of its standard namesake. "A reliable, robust and well consolidated Pneumax product". It has been developed with new, adapted characteristics for inclusion in secure, pneumatic circuits where it is necessary to interrupt the air supply and exhaust the pneumatic system connected to port 4 when the electropneumatic command is de-energised.

The valve is based on balanced spool technology which has 5 ports, 2 positions.

The electro-pneumatic valve is actuated using a 15mm solenoid valve from the Pneumax 300 Series range and repositioned by the internal return spring. It is also possible to operate the electro-operator by combining the electric drive with a monostable manual control.

The air supply used by the solenoid valve can be supplied in 2 different ways;

- **Self Feeding:** supplied directly by the air being controlled (Subject to a minimum pressure)
- **External Feed:** supplied indirectly by an external air supply

The new feature in this version is the introduction of a diagnostic system able to monitor the ON/OFF state of the valve, with the possibility of increasing the level of monitoring using a double redundant system configured on a base which can be installed to control the management of the pneumatic connections.

The state of the valve is constantly monitored by a diagnostic system using a hall effect sensor with a 2.5mtr, 3 wire cable, which reads the position of the spool and consequently the ON/OFF state.

- **Sensor is in the ON position** when the valve is at rest;
- **Sensor is in the OFF position** when the valve is activated

OPERATION OF THE ISO1, ISO2, ISO3 VERSION WITH SINGLE CHANNEL, S.V. 5/2 MONOSTABLE WITH ELECTROPNEUMATIC COMMAND AND SPRING RETURN:

Phases:

- **VALVE AT REST:** the coil is DE-ENERGISED, port 1 (air supply) is connected to port 2 (downstream air circuit), port 3 is closed, port 4 (downstream air circuit) is connected to port 5 and exhausted;
- **VALVE ACTIVATED:** the coil is ENERGISED, port 1 (air supply) is connected to port 4 (downstream air circuit), port 5 is closed, port 2 (downstream air circuit) is connected to port 3 and exhausted.

By de-energising the coil, the system resets the condition of VALVE AT REST by means of the return spring, which repositions the spool. Once again port 4 (downstream air circuit), exhaust via port 5, port 1 supplies the port 2 (downstream pneumatic circuit) again, port 3 closes.

The electrical connection is provided through the connector for micro S.V. CNOMO of the Series 300. IP Rating, "with connector installed" is IP65.

The SAFELINE supply and discharge valve in the single version is a classified component in CATEGORY 2 according to ISO EN 13849 and is appropriate for use in safety circuits until PL=C.

The version with a double redundant version is made using two single solenoid valves 5/2 N.C. provided with diagnostics, mounted so that the Ports 2 are in parallel and Ports 4 are in series. It is sufficient that only one of the S.V. is de-energised to guarantee the exhausting of the air circuit. If one of the two S.V. must remain blocked due to a malfunction, the other one ensures the exhaust function of the pneumatic installation. Even in this case, the diagnostic system of both solenoid valves constantly monitors the state of the 2 single S.V.

The SAFELINE supply and discharge valve in the double version is a classified component in CATEGORY 4 according to ISO EN 13849 and is appropriate for use in safety circuits until PL=E.

Both single and double solenoid valves are provided with the following certifications released by BUREAU VERITAS:

- TYPE APPROVAL certificate according to the EN ISO 13849 regulations
- certification of examination of compliance in accordance to the machinery directive 2006/42/CE

The AIRPLUS SAFELINE are solenoid valves marked as ATEX



II 3G Ex h IIB T4 Gc (X)
II 3D Ex h IIIC T135°C Dc (X) IP65
(-10°C ≤ Ta ≤ +50°C)



Construction characteristics

	ISO 1	ISO 2	ISO 3
Body	Technopolymer	Technopolymer	Die-cast aluminum
Solenoid operator	Aluminium	Aluminium	Aluminium
Rear end cap	Technopolymer	Technopolymer	Aluminium
Spool	Steel	Steel	Steel
Spool seals	NBR	NBR	NBR
Spacers	Technopolymer	Technopolymer	Aluminium
Piston	Aluminium	Aluminium	Aluminium
Spring	Steel	Steel	Steel
Electrical Interface	22/30mm connector	22/30mm connector	22/30mm connector

Operational characteristics

Description	Value
Fluid	Filtered air, if lubricated, the lubrication must be continuous
Working Temperature	-10°C - +50°C
Working Pressure, MIN	2,5 bar
Working Pressure, MAX	10 bar

Assembly and installation

Undertake the installation respecting the safety requirements with regards to the system and components far hydraulic and pneumatic transmissions. Install the device as close as possible to the point of use. Its assembly is possible in any position. Pay attention to the flow direction, following the port numbers on the valve body . During the components discharge, high levels of noise occur. The use of a silencer on the discharge port is recommended. Ensure there is sufficient space far assembly during the installation process. Please ensure that the discharge area is always clear, and in case a silencer is used, periodically verify that it is not obstructed.

WARNING:



Pay particular attention to external factors such as the nearness of live wires, magnetic fields, metallic objects providing magnetic conduction very close to the device, which may influence and disturb the diagnostic system.



The electrical connection must be made exclusively by qualified personnel, using components that have no voltage present. Only use power supplies which can guarantee a safe electrical isolation of the working voltage in accordance to IEC/EN 60204-1. Additionally, observe the requirements anticipated by the PELV circuits in accordance to IEC/EN 60204-1.

CARE AND MAINTENANCE:



Do not connect or disconnect the device when energised! Do not open and/or disassemble the parts that are included in the energised valve. Once the power supply is disconnected, wait for a few minutes before opening or disassembling parts of the valve that result in its disassembly.

Before carrying out any operation, it is essential to remove the pneumatic and power supply to the device and wait for the residual pressure to be completely discharged. Please ensure that the discharge is always clear, and in case a silencer is used, periodically verify that it is not obstructed. Periodically remove any dust deposits from the valve using a damp cloth. Use soapy water to clean the device. Do not use corrosive or alcohol-based products. For maintenance operations on internal components, please consult with PNEUMAX SPA.



REGULATORY FRAMEWORK:

The purpose of the EU' s Machinery Directive is to define the health and safety requirements in the framework of designing and constructing machinery. Since 2009, the new Machinery Directive has become effective in the European Union. Member countries of the EU are required to implement this standard. The manufacturers of machinery can comply with the Machinery Directive applying the harmonised standards listed in the Official Journal of the European Union. The design and manufacture of safety controls are developed in compliance with one of the two important harmonised standards:

UNI EN ISO 13849-1
Safety of machinery Safety-related parts of control systems Part 1: General design principles

EN 62061
Safety of machinery Functional safety of electrical, electronic and programmable control systems regarding safety

The UNI EN ISO 13849-1 standard is one of the most important harmonised standards, which has been widely used; it is intended to provide a guide to principles for design and integration of safety-related parts of the control system.

Each safety-related control system must be designed and constructed in accordance with the principles of ISO 12100 and ISO 14121 by which the possible risks are considered and assessed, in view of the intended uses and the reasonably anticipated incorrect uses.

The parts of a machinery' s control system are called "Safety-related parts of control systems". Their capacity to perform a safety function under predictable conditions is assigned by means of five possible levels called "**performance levels**" (PL). These levels are defined in terms of probability of dangerous malfunction per hour.

PL - Performance Level	Average probability of dangerous malfunction per hour (1/h)
a	$\geq 10^{-5}$ to $< 10^{-4}$
b	$\geq 3 \times 10^{-6}$ to $< 10^{-4}$
c	$\geq 10^{-6}$ to $< 3 \times 10^{-6}$
d	$\geq 10^{-7}$ to $< 10^{-6}$
e	$\geq 10^{-8}$ to $< 10^{-10}$

The calculated PL must be greater or equal to the necessary value, which arises from the calculation of the risk correlated to one single function and to the need to reduce it to an acceptable level:

S1 Slight danger	F1 Occasional danger and brief exposure	P1 - possibly avoidable danger P2 - largely unavoidable danger	PL = a PL = b
	F2 Frequent danger and long exposure	P1 - possibly avoidable danger P2 - largely unavoidable danger	
S2 Serious danger	F1 Occasional danger and brief exposure	P1 - possibly avoidable danger P2 - largely unavoidable danger	PL = c PL = d
	F2 Frequent danger and long exposure	P1 - possibly avoidable danger P2 - largely unavoidable danger	



Single version 5/2 Solenoid-Spring (ISO1, ISO2, ISO3)



SOLENOID VALVES



Ordering code	
101 Ⓢ . 52 . Ⓥ . VSB . ⓐ	
SIZE	
Ⓢ	1 = ISO 1
	2 = ISO 2
	3 = ISO 3
AIR SUPPLY	
Ⓥ	39 = Self Feeding
	29 = External Feed
COILS	
	B04 = 22 mm Type MB 12 V DC
	B05 = 22 mm Type MB 24 V DC
	B56 = 22 mm Type MB 24 V AC (50 - 60 Hz)
	B57 = 22 mm Type MB 110 V AC (50 - 60 Hz)
ⓐ	B58 = 22 mm Type MB 230 V AC (50 - 60 Hz)
	C05 = 30 mm Type MC 24 V DC
	C56 = 30 mm Type MC 24 V AC (50 - 60 Hz)
	C57 = 30 mm Type MC 110 V AC (50 - 60 Hz)
	C58 = 30 mm Type MC 230 V AC (50 - 60 Hz)
Weight: ISO1 650 g, ISO2 850 g, ISO3 2000 g	
Minimum working pressure 2,5 bar	

General technical features	ISO 1	ISO 2	ISO 3
UNI-ISO 228/1 connections	G 1/4"	G 3/8"	G 1/2"
Fluid	Filtered air, if lubricated, the lubrication must be continuous		
Function	5/2 N.C. monostable		
Working pressure	Vacuum - 10 bar		
Piloting pressure	2,5 bar - 10 bar		
Working temperature	-10°C - +50°C		
Flow rate from 1 → 2 at 6 bar Δp1	900 NI/min	1600 NI/min	3600 NI/min
Flow rate from 2 → 3 at 6 bar Δp1	900 NI/min	1800 NI/min	3600 NI/min
Flow rate from 2 → 3 at 6 bar with free discharge	1500 NI/min	3000 NI/min	6100 NI/min
Type of installation	Indifferent		
Mounting	With individual bases according to standard ISO 5599/1		
Noise level (with silenced exhaust)	70 dB	70 dB	75 dB
Response time ON ISO 12238 (TRA)	24 ms	23 ms	40 ms
Response time OFF ISO 12238 (TRR)	70 ms	75 ms	150 ms
General electrical features			
Solenoid valve	According to standard CNOMO		
Electrical connection	30 mm connector DIN 43650 "A" SHAPE		
	22 mm connector DIN 43650 "INDUSTRIAL" SHAPE		
Coil features	30 mm	4,8 W 24 VDC 7,5 VA; 24 VAC; 110 VAC; 230 VAC a 50/60 Hz	
	22 mm	5,5 W 24 VDC; 5,5 W 12 VDC 5,5 VA 24 VAC; 110 VAC; 230 VAC A 50/60 Hz	
Supply voltage allowance	-5% / +10%		
IP Rating	IP65 (with connector installed)		
Electrical features of sensor			
Voltage range	10 - 30 V DC		
Operating principle	Hall effect		
Contact type	N.O.		
Output type	PNP		
Permanent maximum current	100 mA		
Permanent maximum power	3 W max.		
Maximum load (inductive)	3 W max.		
Voltage drop, MAX	1.5 V max.		
Cable section	3x0.14 mm ² Ø3.3mm PUR		
IP Rating	IP67		
Working temperature	-10°C / + 70°C		
Safety features			
Regulatory compliance	EN ISO 13849-1		
Safety function fulfilled	Interruption of supply and discharge of the pneumatic circuit connected to port 4		
Performance Level (PL)	Up to c		
UNI EN 13849 Category	Up to 2		
Safety Integrity Level (SIL)	Up to 1		
B10d Expected	15 x 10 ⁶ cycles		
ATTENTION: in accordance with UNI EN ISO 13849-1, the T10D value must be calculated by the final system integrator based on the number of cycles per year of the components. In any case, the components must be replaced every twenty years.			
CE Marking	Safety component according to directive 2006/42/CE		

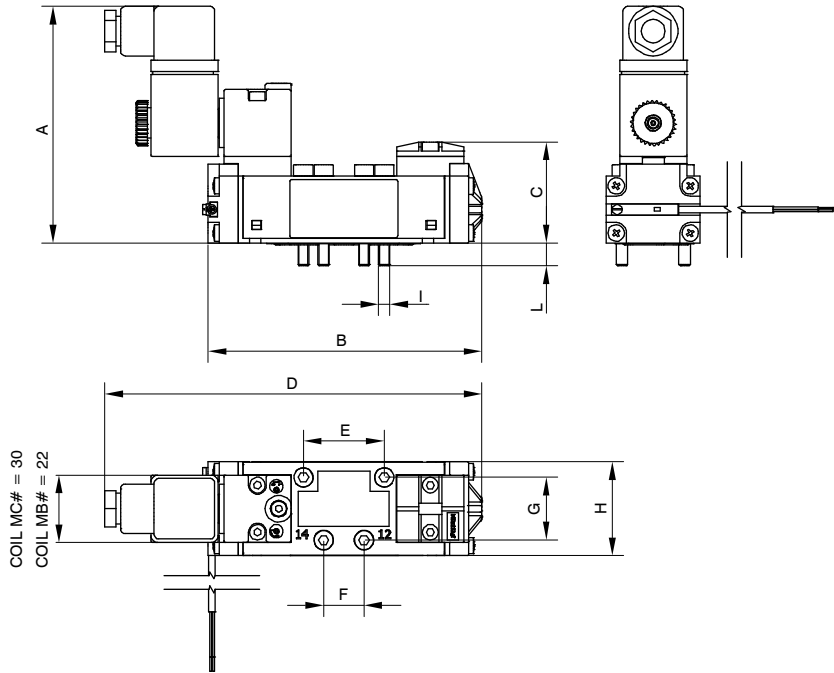
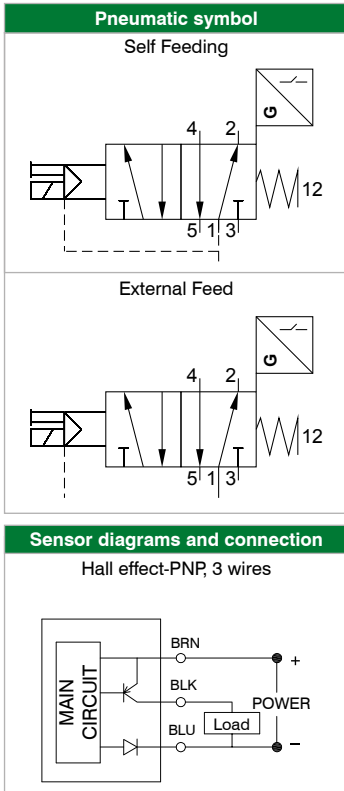

Size	ISO 1	ISO 2	ISO 3
A (MC#)	105.5	108.5	120
A (MB#)	99	102	113.5
B	122	147.2	171.2
C	45	48.4	59.5
D	168	191.5	222.5
E	36	48	64
F	18	24	32
G	28	38	48
H	42	52.5	66
I	M5	M6	M8
L	10	8	14.5

SOLENOID VALVES



Single use bases

Size 1 - shape "A"

Ordering code

1101.14

weight 160 g

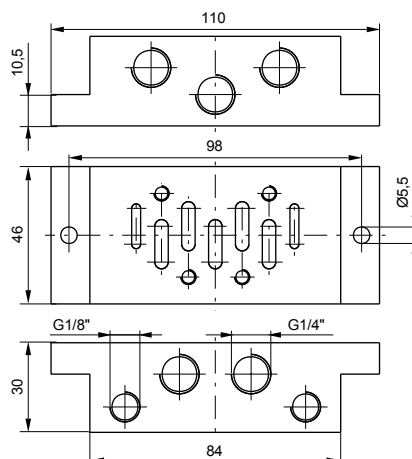

Size 2 - shape "A"

Ordering code

1102.14

weight 190 g

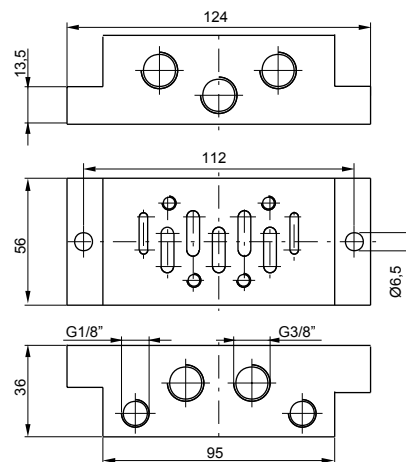
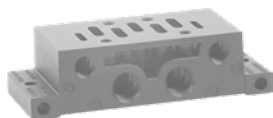

Size 3 - shape "A"

Ordering code

1103.14

weight 600 g

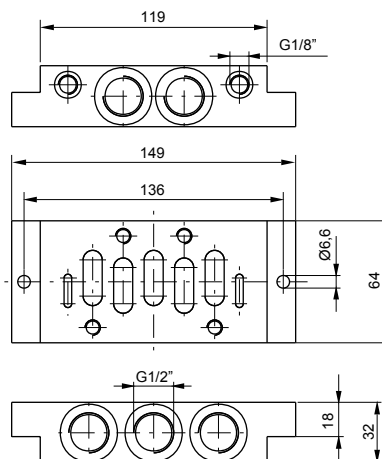



Double version 5/2 Solenoid-Spring (ISO1, ISO2, ISO3)

Ordering code	
101 V2SB	
SIZE	
	1 = ISO 1
	2 = ISO 2
	3 = ISO 3
AIR SUPPLY	
	39 = Self Feeding
	29 = External Feed
COILS	
	B04 = 22 mm Type MB 12 V DC
	B05 = 22 mm Type MB 24 V DC
	B56 = 22 mm Type MB 24 V AC (50 - 60 Hz)
	B57 = 22 mm Type MB 110 V AC (50 - 60 Hz)
	B58 = 22 mm Type MB 230 V AC (50 - 60 Hz)
	C05 = 30 mm Type MC 24 V DC
	C56 = 30 mm Type MC 24 V AC (50 - 60 Hz)
	C57 = 30 mm Type MC 110 V AC (50 - 60 Hz)
	C58 = 30 mm Type MC 230 V AC (50 - 60 Hz)
Weight: ISO1 2200 g, ISO2 4000 g, ISO3 7000 g	
Minimum working pressure 2,5 bar	



General technical features	ISO 1	ISO 2	ISO 3
UNI-ISO 228/1 connections	G 1/4"	G 3/8"	G 1/2"
Fluid	Filtered air, if lubricated, the lubrication must be continuous		
Function	5/2 N.C. monostable		
Working pressure	Vacuum - 10 bar		
Piloting pressure	2,5 bar - 10 bar		
Working temperature	-10°C - +50°C		
Flow rate from 1 → 2 at 6 bar Δp1	700 NI/min	1300 NI/min	2800 NI/min
Flow rate from 2 → 3 at 6 bar Δp1	700 NI/min	1400 NI/min	2800 NI/min
Flow rate from 2 → 3 at 6 bar with free discharge	1200 NI/min	2600 NI/min	5500 NI/min
Type of installation	Indifferent		
Noise level (with silenced exhaust)	70 dB	70 dB	75 dB
Response time ON ISO 12238 (TRA)	44 ms	48 ms	88 ms
Response time OFF ISO 12238 (TRR)	70 ms	71 ms	146 ms
General electrical features			
Solenoid valve	According to standard CNOMO		
Electrical connection	30 mm connector DIN 43650 "A" SHAPE		
	22 mm connector DIN 43650 "INDUSTRIAL" SHAPE		
Coil features	30 mm	4,8 W 24 VDC 7,5 VA; 24 VAC; 110 VAC; 230 VAC a 50/60 Hz	
	22 mm	5,5 W 24 VDC; 5,5 W 12 VDC 5,5 VA 24 VAC; 110 VAC; 230 VAC A 50/60 Hz	
Supply voltage allowance	-5% / +10%		
IP Rating	IP65 (with connector installed)		
Electrical features of sensor			
Voltage range	10 - 30 V DC		
Operating principle	Hall effect		
Contact type	N.O.		
Output type	PNP		
Permanent maximum current	100 mA		
Permanent maximum power	3 W max.		
Maximum load (inductive)	3 W max.		
Voltage drop, MAX	1.5 V max.		
Cable section	3x0.14 mm ² Ø3.3mm PUR		
IP Rating	IP67		
Working temperature	-10°C / + 70°C		
Safety features			
Regulatory compliance	EN ISO 13849-1		
Safety function fulfilled	Interruption of supply and discharge of the pneumatic circuit connected to port 4		
Performance Level (PL)	Up to e		
UNI EN 13849 Category	Up to 4		
Safety Integrity Level (SIL)	Up to 3		
B10d Expected	15 x 10 ⁶ cycles		
ATTENTION: in accordance with UNI EN ISO 13849-1, the T10D value must be calculated by the final system integrator based on the number of cycles per year of the components. In any case, the components must be replaced every twenty years.			
CE Marking	Safety component according to directive 2006/42/CE		

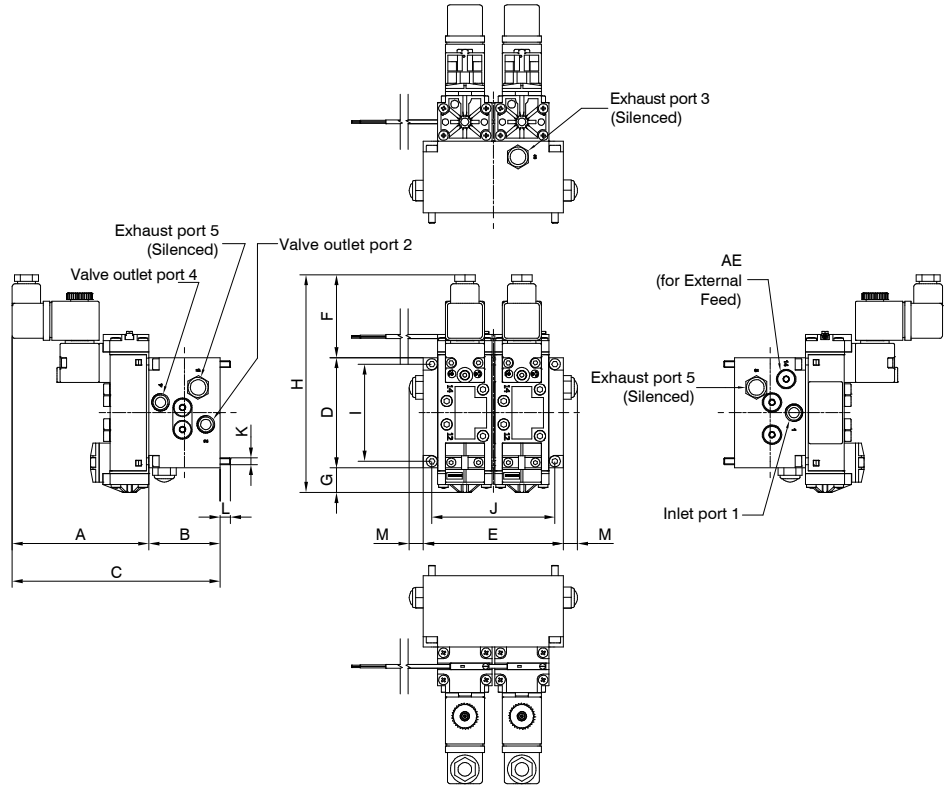
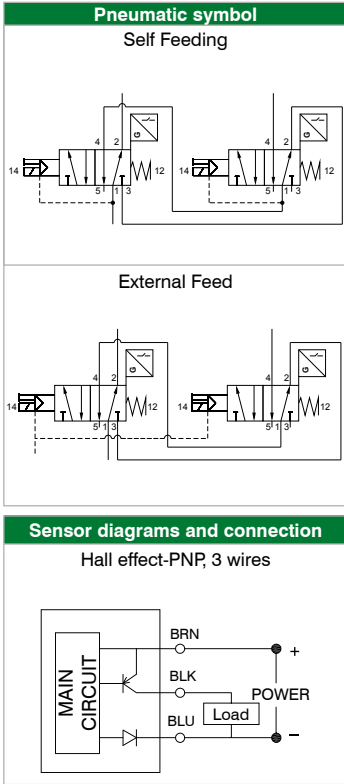

Size	ISO 1	ISO 2	ISO 3
Inlet port 1	G 1/4"	G 3/8"	G 1/2"
Valve outlet port 2	G 1/4"	G 3/8"	G 1/2"
Valve outlet port 4	G 1/4"	G 3/8"	G 1/2"
Exhaust port 3	G 1/4"	G 3/8"	G 1/2"
Exhaust port 5	G 1/4"	G 3/8"	G 1/2"
AE	G 1/4"	G 1/4"	G 3/8"
A (MC#)	105.5	108.5	120
A (MB#)	99	102	113.5
B	55	68	75
C (MC#)	160.5	176.5	195
C (MB#)	154	170	188.5
D	85	115	140
E	108	150	180
F	64	58.5	55
G	19	18	27.5
H (MC#)	168	191.5	222.5
H (MB#)	172	191.5	226.5
I	75	100	120
J	95	130	160
K	M5	M8	M10
L	8	12	15
M	11	10.5	14



PNEUMAX

PNEUMAX S.p.A.

Via Cascina Barbellina, 10
24050 Lurano (BG) - Italy
P. +39 035 41 92 777
info@pneumaxspa.com